

To use a **Just Right Light®** ballast with less lamps than it is designed for, simply take any pair of lamp wires except yellow, snip the pre-stripped ends, and put a wire connector on them.

Although you may think that they should be twisted together first, you do NOT twist them together. You just leave them hanging, but snip the end and cap it to prevent accidental shorting. Intentionally twisting them together will destroy the ballast as soon as the electricity is turned on.

Avoid the temptation to snip the wires close to the ballast housing, as this may void the warranty.

Standard Wiring Diagrams

Two Lamp Ballast

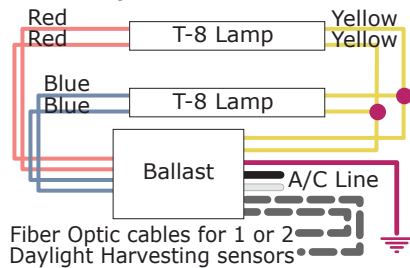

● = Wire Connector

Three Lamp Ballast

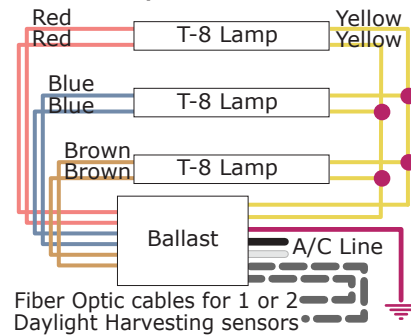

Four Lamp Ballast

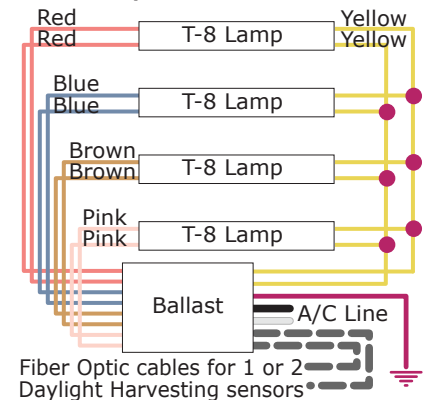

Alternate Wiring Diagrams

2 Lamps with 3 Lamp Ballast

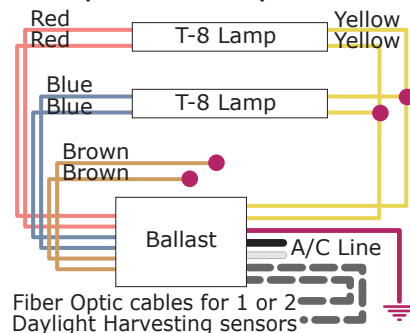

● = Wire Connector

2 Lamps with 4 Lamp Ballast

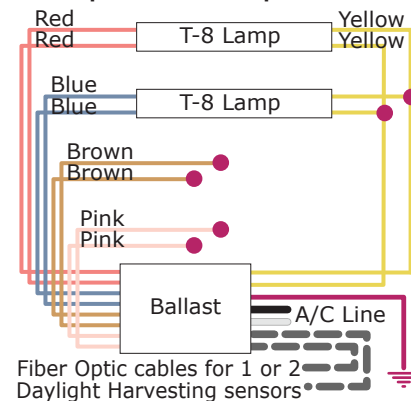

3 Lamps with 4 Lamp Ballast

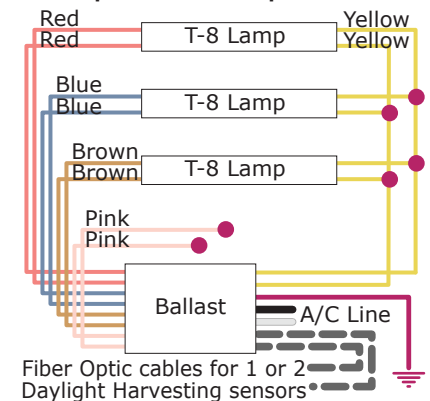

NOTE: Lamps must be "Burned-In" for 100 hours before dimming. Disconnect A/C Current before installing or servicing. In addition to the safety issue, installing these ballasts on a live circuit can damage the internal electronics, and may void your warranty.